

Tuned Amplifiers

UNIT -III

The types of amplifiers that we have discussed so far cannot work effectively at radio frequencies, even though they are good at audio frequencies. Also, the gain of these amplifiers is such that it will not vary according to the frequency of the signal, over a wide range. This allows the amplification of the signal equally well over a range of frequencies and does not permit the selection of particular desired frequency while rejecting the other frequencies.

So, there occurs a need for a circuit which can select as well as amplify. So, an amplifier circuit along with a selection, such as a tuned circuit makes a **Tuned amplifier**.

Amplifiers which amplify a specific frequency or narrow band of frequencies are called **tuned amplifiers**. **Tuned amplifiers** are mostly used for the amplification of high or radio frequencies. It is because radio frequencies are generally single and the **tuned** circuit permits their selection and efficient amplification. Tuning (i.e., selecting) of frequency is done by using a **tuned** or resonant circuit at the load.

What is a Tuned Amplifier?

Tuned amplifiers are the amplifiers that are employed for the purpose of **tuning**. Tuning means selecting. Among a set of frequencies available, if there occurs a need to select a particular frequency, while rejecting all other frequencies, such a process is called **Selection**. This selection is done by using a circuit called as **Tuned circuit**.

When an amplifier circuit has its load replaced by a tuned circuit, such an amplifier can be called as a **Tuned amplifier circuit**. The basic tuned amplifier circuit looks as shown below.

The tuner circuit is nothing but a LC circuit which is also called as **resonant** or **tank circuit**. It selects the frequency. A tuned circuit is capable of amplifying a signal over a narrow band of frequencies that are centered at resonant frequency.

When the reactance of the inductor balances the reactance of the capacitor, in the tuned circuit at some frequency, such a frequency can be called as **resonant frequency**. It is denoted by f_r .

The formula for resonance is

$$X_L = X_C$$

$$f_r = 1 / 2\pi\sqrt{LC}$$

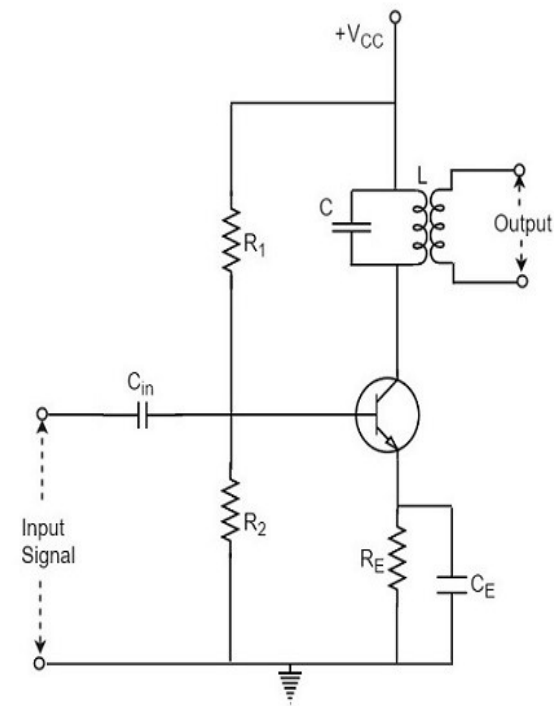

Types of Tuned Circuits

A tuned circuit can be Series tuned circuit (Series resonant circuit) or Parallel tuned circuit (parallel resonant circuit) according to the type of its connection to the main circuit.

Series Tuned Circuit

The inductor and capacitor connected in series make a series tuned circuit, as shown in the following circuit diagram.



At resonant frequency, a series resonant circuit offers low impedance which allows high current through it. A series resonant circuit offers increasingly high impedance to the frequencies far from the resonant frequency.

Parallel Tuned Circuit

The inductor and capacitor connected in parallel make a parallel tuned circuit, as shown in the below figure.

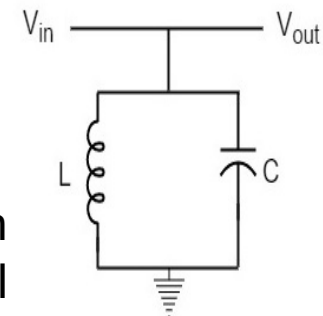

At resonant frequency, a parallel resonant circuit offers high impedance which does not allow high current through it. A parallel resonant circuit offers increasingly low impedance to the frequencies far from the resonant frequency.

Characteristics of a Parallel Tuned Circuit

The frequency at which parallel resonance occurs (i.e. reactive component of circuit current becomes zero) is called the resonant frequency f_r . The main characteristics of a tuned circuit are as follows.

Impedance

The ratio of supply voltage to the line current is the impedance of the tuned circuit. Impedance offered by LC circuit is given by

$$\text{Impedance} = \text{Supply Voltage} / \text{Line Current}$$

At resonance, the line current increases while the impedance decreases.

The below figure represents the impedance curve of a parallel resonance circuit.

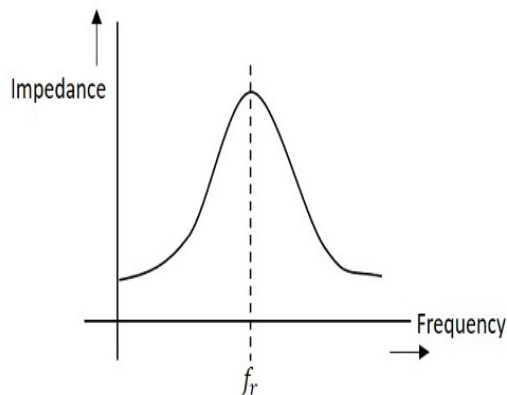

Impedance of the circuit decreases for the values above and below the resonant frequency f_r . Hence the selection of a particular frequency and rejection of other frequencies is possible.

To obtain an equation for the circuit impedance, let us consider

Line Current $I = I_L \cos\phi$.

$$\frac{V}{Z_r} = \frac{V}{Z_L} \times \frac{R}{Z_L}$$

$$\frac{1}{Z_r} = \frac{R}{Z_L^2}$$

$$\frac{1}{Z_r} = \frac{R}{L/C} = \frac{RC}{L}$$

$$Z_L^2 = \frac{L}{C}$$

Therefore, circuit impedance Z_r is obtained as

$$Z_R = \frac{L}{RC}$$

Thus at parallel resonance, the circuit impedance is equal to L/CR .

Circuit Current

At parallel resonance, the circuit or line current I is given by the applied voltage divided by the circuit impedance Z_r i.e.,

$$\text{Line Current} \quad I = \frac{V}{Z_r}$$
$$Z_R = \frac{L}{RC}$$

Because Z_r is very high, the line current I will be very small.

Quality Factor

For a parallel resonance circuit, the sharpness of the resonance curve determines the selectivity. The smaller the resistance of the coil, the sharper the resonant curve will be. Hence the inductive reactance and resistance of the coil determine the quality of the tuned circuit.

The ratio of inductive reactance of the coil at resonance to its resistance is known as **Quality factor**. It is denoted by **Q**.

$$Q = \frac{X_L}{R} = \frac{2\pi f_r L}{R}$$

The higher the value of Q , the sharper the resonance curve and the better the selectivity will be.

Advantages of Tuned Amplifiers

The following are the advantages of tuned amplifiers.

- The usage of reactive components like L and C, minimizes the power loss, which makes the tuned amplifiers efficient.
- The selectivity and amplification of desired frequency is high, by providing higher impedance at resonant frequency.
- A smaller collector supply VCC would do, because of its little resistance in parallel tuned circuit.

It is important to remember that these advantages are not applicable when there is a high resistive collector load.

Frequency Response of Tuned Amplifier

For an amplifier to be efficient, its gain should be high. This voltage gain depends upon β , input impedance and collector load. The collector load in a tuned amplifier is a tuned circuit.

The voltage gain of such an amplifier is given by $\text{Voltage gain} = \frac{\beta Z_c}{Z_{in}}$

Where Z_c = effective collector load and Z_{in} = input impedance of the amplifier.

The value of Z_c depends upon the frequency of the tuned amplifier. As Z_c is maximum at resonant frequency, the gain of the amplifier is maximum at this resonant frequency.

Bandwidth

The range of frequencies at which the voltage gain of the tuned amplifier falls to 70.7% of the maximum gain is called its **Bandwidth**.

The range of frequencies between f_1 and f_2 is called as bandwidth of the tuned amplifier. The bandwidth of a tuned amplifier depends upon the Q of the LC circuit i.e., upon the sharpness of the frequency response. The value of Q and the bandwidth are inversely proportional.

The figure below details the bandwidth and frequency response of the tuned amplifier.

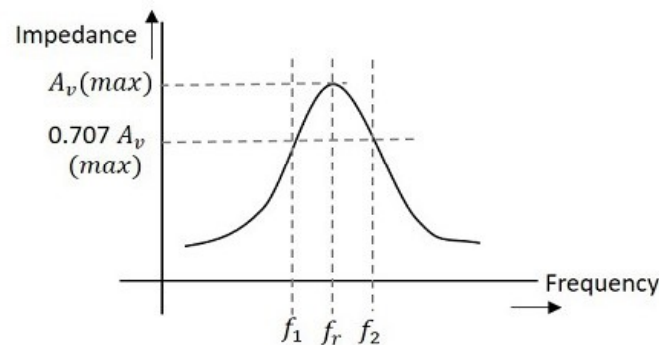

Relation between Q and Bandwidth

The quality factor Q of the bandwidth is defined as the ratio of resonant frequency to bandwidth, i.e.,

$$Q = \frac{f_r}{BW}$$

In general, a practical circuit has its Q value greater than 10.

Under this condition, the resonant frequency at parallel resonance is given by

$$f_r = \frac{1}{2\pi\sqrt{LC}}$$

There are two main types of tuned amplifiers. They are –

- Single tuned amplifier
- Double tuned amplifier

Single Tuned Amplifier

An amplifier circuit with a single tuner section being at the collector of the amplifier circuit is called as Single tuner amplifier circuit.

Construction

A simple transistor amplifier circuit consisting of a parallel tuned circuit in its collector load, makes a single tuned amplifier circuit. The values of capacitance and inductance of the tuned circuit are selected such that its resonant frequency is equal to the frequency to be amplified.

The following circuit diagram shows a single tuned amplifier circuit.

The output can be obtained from the coupling capacitor C_C as shown above or from a secondary winding placed at L .

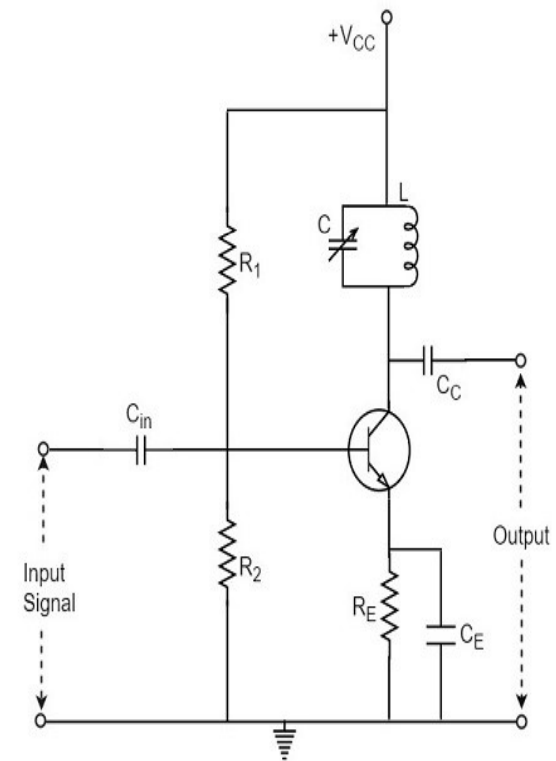

Operation

The high frequency signal that has to be amplified is applied at the input of the amplifier. The resonant frequency of the parallel tuned circuit is made equal to the frequency of the signal applied by altering the capacitance value of the capacitor C, in the tuned circuit.

At this stage, the tuned circuit offers high impedance to the signal frequency, which helps to offer high output across the tuned circuit. As high impedance is offered only for the tuned frequency, all the other frequencies which get lower impedance are rejected by the tuned circuit. Hence the tuned amplifier selects and amplifies the desired frequency signal.

Frequency Response

The parallel resonance occurs at resonant frequency f_r when the circuit has a high Q. the resonant frequency f_r is given

$$f_r = \frac{1}{2\pi\sqrt{LC}}$$

The following graph shows the frequency response of a single tuned amplifier circuit.

At resonant frequency f_r the impedance of parallel tuned circuit is very high and is purely resistive. The voltage across R_L is therefore maximum, when the circuit is tuned to resonant frequency. Hence the voltage gain is maximum at resonant frequency and drops off above and below it. The higher the Q, the narrower will the curve be.

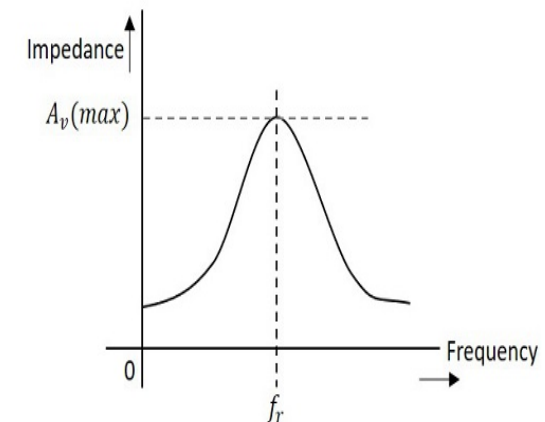

Double Tuned Amplifier

An amplifier circuit with a double tuner section being at the collector of the amplifier circuit is called as Double tuned amplifier circuit.

Construction

The construction of double tuned amplifier is understood by having a look at the following figure. This circuit consists of two tuned circuits L_1C_1 and L_2C_2 in the collector section of the amplifier. The signal at the output of the tuned circuit L_1C_1 is coupled to the other tuned circuit L_2C_2 through mutual coupling method. The remaining circuit details are same as in the single tuned amplifier circuit, as shown in the following circuit diagram.

Operation

The high frequency signal which has to be amplified is given to the input of the amplifier. The tuning circuit L_1C_1 is tuned to the input signal frequency. At this condition, the tuned circuit offers high reactance to the signal frequency. Consequently, large output appears at the output of the tuned circuit L_1C_1 which is then coupled to the other tuned circuit L_2C_2 through mutual induction. These double tuned circuits are extensively used for coupling various circuits of radio and television receivers.

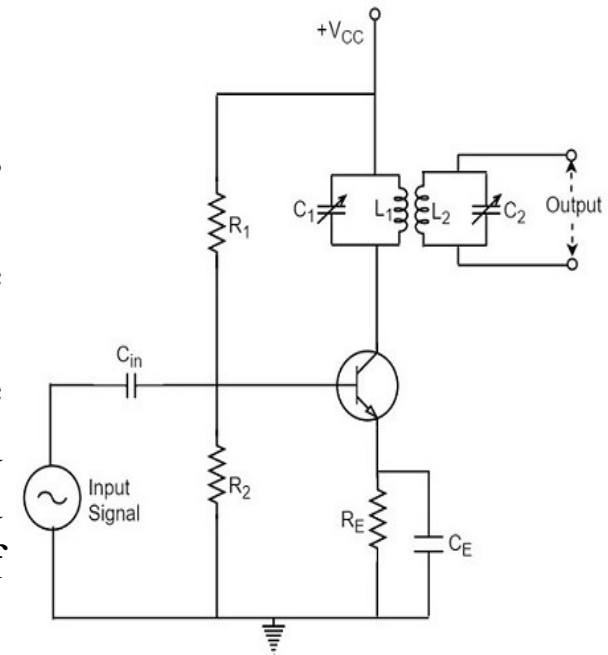

Frequency Response of Double Tuned Amplifier

The double tuned amplifier has the special feature of **coupling** which is important in determining the frequency response of the amplifier. The amount of mutual inductance between the two tuned circuits states the degree of coupling, which determines the frequency response of the circuit.

In order to have an idea on the mutual inductance property, let us go through the basic principle.

Mutual Inductance

As the current carrying coil produces some magnetic field around it, if another coil is brought near this coil, such that it is in the magnetic flux region of the primary, then the varying magnetic flux induces an EMF in the second coil. If this first coil is called as **Primary coil**, the second one can be called as a **Secondary coil**.

When the EMF is induced in the secondary coil due to the varying magnetic field of the primary coil, then such phenomenon is called as the **Mutual Inductance**.

The figure below gives an idea about this.

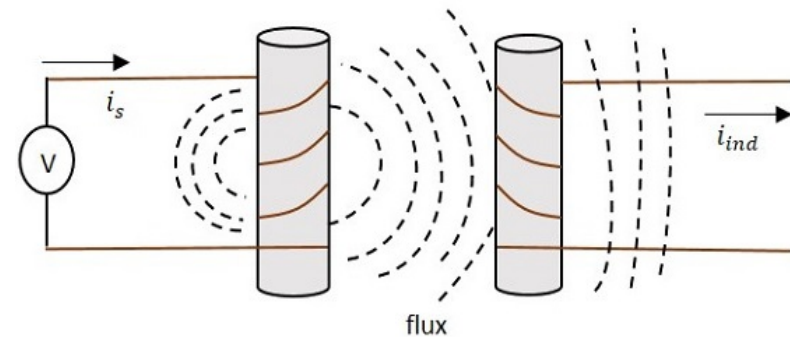

Coupling

Under the concept of mutual inductance coupling will be as shown in the figure below.

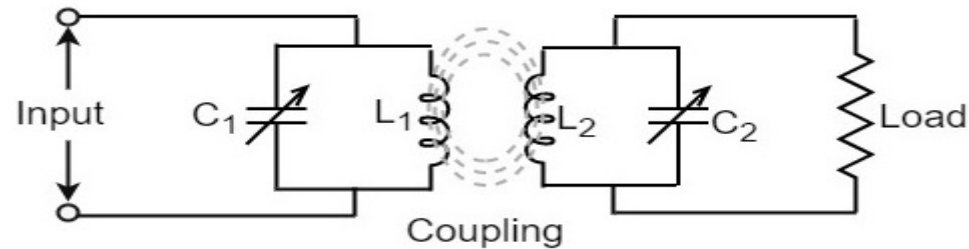

When the coils are spaced apart, the flux linkages of primary coil L_1 will not link the secondary coil L_2 . At this condition, the coils are said to have **Loose coupling**. The resistance reflected from the secondary coil at this condition is small and the resonance curve will be sharp and the circuit Q is high as shown in the figure below.

On the contrary, when the primary and secondary coils are brought close together, they have **Tight coupling**. Under such conditions, the reflected resistance will be large and the circuit Q is lower. Two positions of gain maxima, one above and the other below the resonant frequency are obtained.

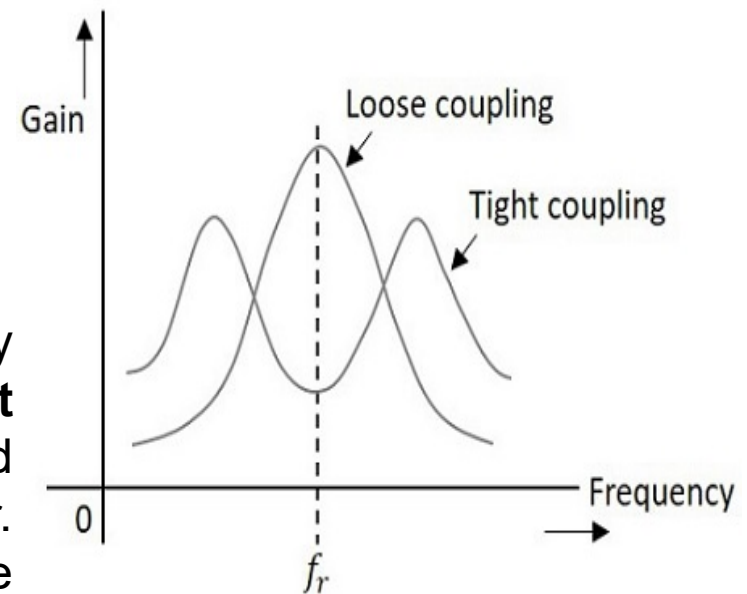

Bandwidth of Double Tuned Circuit

The above figure clearly states that the bandwidth increases with the degree of coupling. The determining factor in a double tuned circuit is not Q but the coupling.

We understood that, for a given frequency, the tighter the coupling the greater the bandwidth will be.

The equation for bandwidth is given as

$$BW_{dt} = kf_r$$

Where BW_{dt} = bandwidth for double tuned circuit, K = coefficient of coupling, and f_r = resonant frequency.

We hope that now you have gained sufficient knowledge regarding the functioning of tuned amplifiers. In the next chapter, we will learn about feedback amplifiers.

Stagger Tuned Amplifier:

These amplifiers are useful to amplify the signal for a particular frequency range only. And we get more frequency bandwidth in double-tuned than the single tuned. But there is a complex process in the alignment of the double-tuned. So to overcome this amplifier like stagger tuned ” is introduced.

This amplifier is a cascading of single tuned amplifiers. These amplifiers were in cascade form which is having a certain bandwidth and their resonant frequencies set to equal bandwidth of each stage. This type of amplifier gives more bandwidth. The need for a stagger tuned is, the double stage amplifier gives more bandwidth but alignment is a complex process. These amplifiers are introduced to make easier & to get flat bandwidth. The main advantage of the stagger tuned is it has a flat, better and wide frequency characteristic. The below figure shows the bandwidth area coverage of amplifiers like a single tuned and staggers tuned.

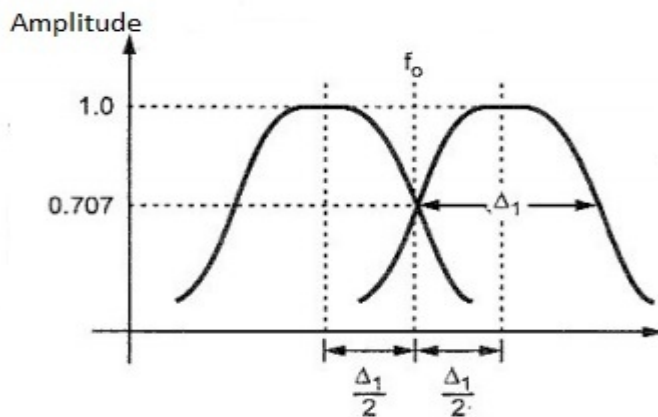

Response of individual tuned amplifier

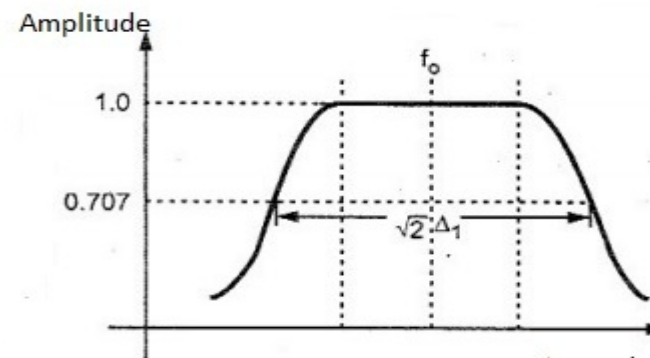

Overall response of stagger tuned amplifier

Advantages

The advantages of this amplifier include the following.

There is a minimum power loss in tuned circuits because in the tuned circuit they use only inductor and capacitor reactive components.

It provides high selectivity.

SNR at the output level is good.

Applications

The applications of this amplifier include the following.

These amplifiers are used to select a particular range of frequencies like in dish, radio, etc.

These amplifiers are used to amplify the desired signal to a high level.

These amplifiers are preferable in [wireless communication](#) systems.

Radio and television broadcastings are very helpful to select a particular range of frequencies.

CHARACTERISTICS OF TUNED AMPLIFIER

- Tuned amplifier selects and amplifies a single frequency from a mixture of frequencies in any frequency range.
- A Tuned amplifier employs a tuned circuit.
- It uses the phenomena of resonance, the tank circuit which is capable of selecting a particular or relative narrow band of frequencies.
- The centre of this frequency band is the resonant frequency of the tuned circuit .
- Both types consist of an inductance L and capacitance C with two element connected in series and parallel.

➤ RESONANCE CIRCUITS:

- When at particular frequency the inductive reactance became equal to capacitive reactance and the circuit then behaves as purely resistive circuit. This phenomenon is called the resonance and the corresponding frequency is called the resonant frequency.

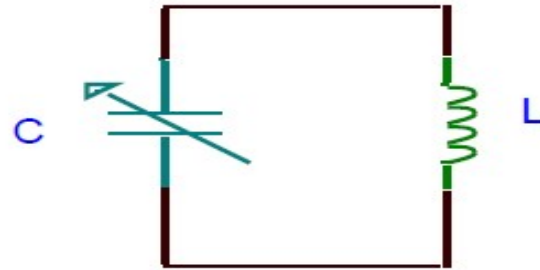

Tu ned c ircuit

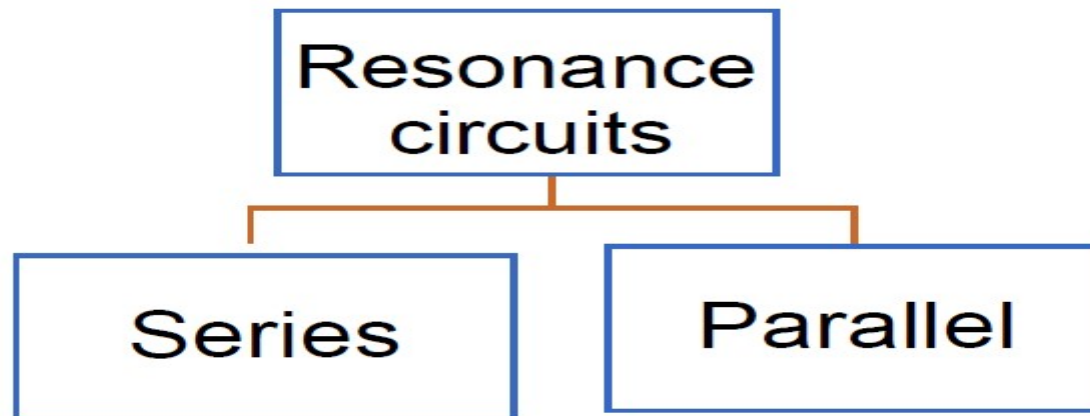

CLASSIFICATION OF TUNED AMPLIFIER

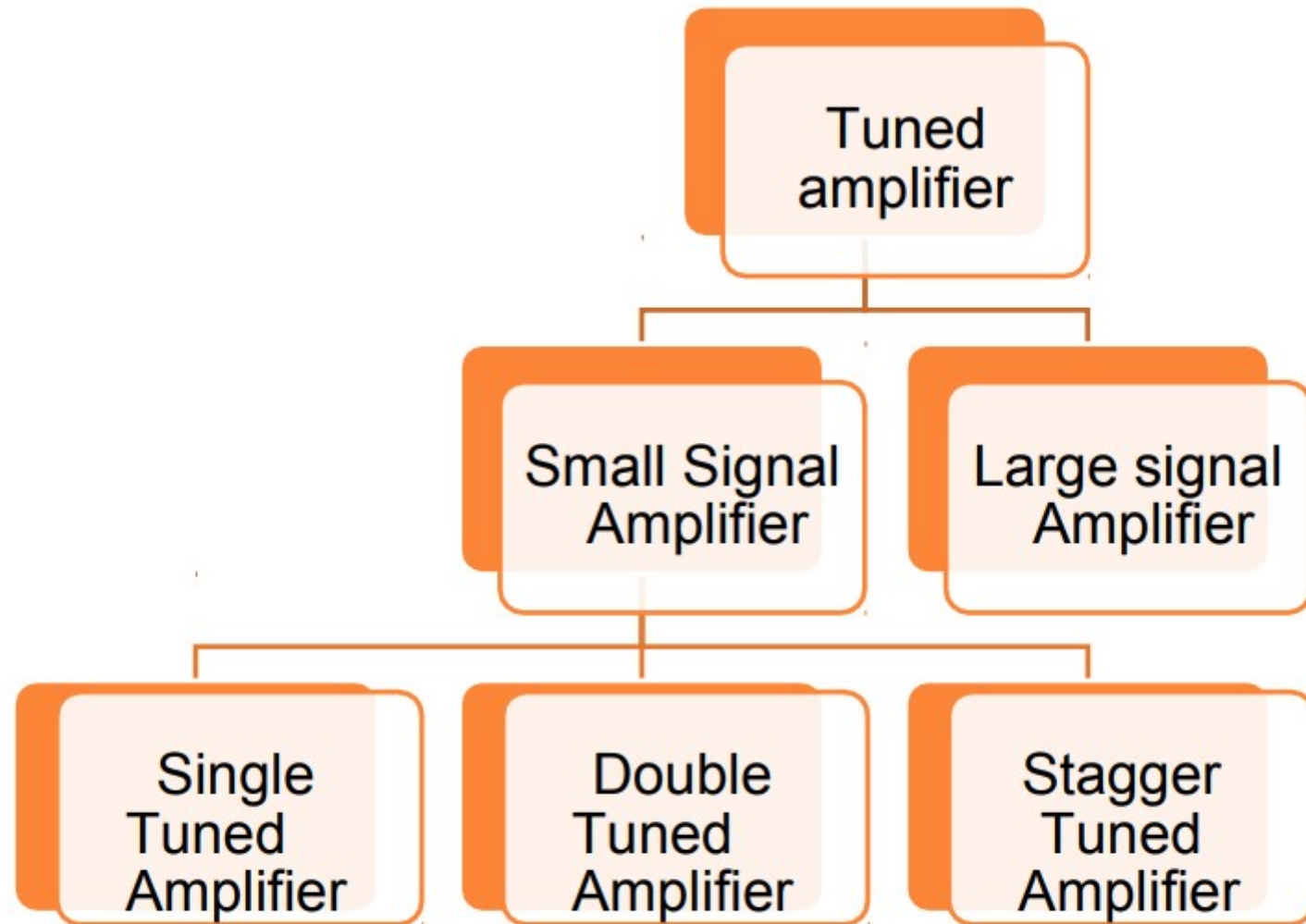

CLASSIFICATION OF TUNED AMPLIFIERS

◦ **Small Signal Tuned Amplifiers** :- They are used to amplify the RF signals of small magnitude.

They are further classified as:

- (a) **Single Tuned Amplifiers**:- In this we use one parallel tuned circuit in each stage.
- (b) **Double Tuned Amplifiers**:- In this we use two mutually coupled tuned circuits for every stage both of tuned circuits are tuned at same freq.
- (c) **Stagger Tuned Amplifiers**:- It is a multistage amplifier which has one parallel tuned circuit for every stage but tuned frequency for all stages

Large signal tuned amplifiers:-

They are meant for amplifying large signals in which large RF power is involved & distortion level is also higher. But tuned circuit itself eliminates most of the harmonic distortion.

➤ SERIES RESONANT CIRCUIT

- It is the circuit in which all the resistive and reactive components are in series.

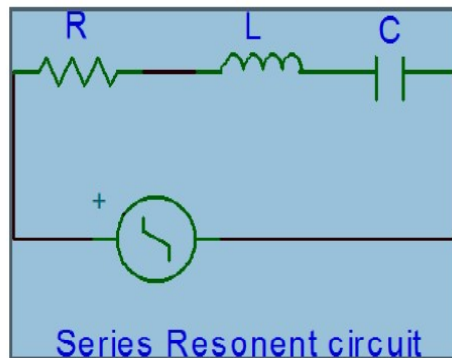

➤ SERIES RESONANT LC

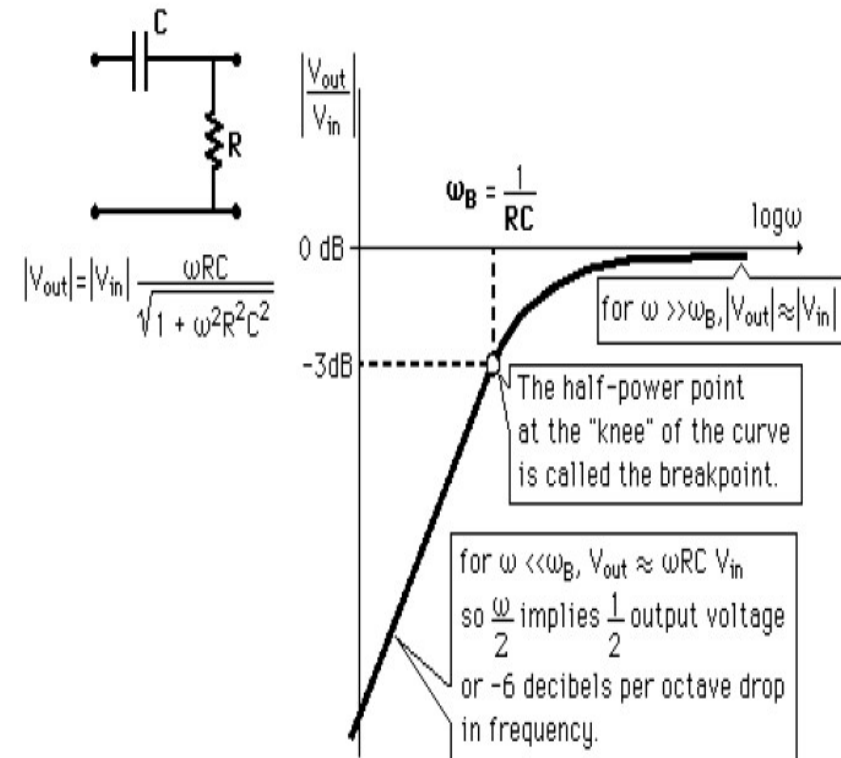

➤ SERIES RESONANT CIRCUIT:

- Impedance Of The Circuit: - $Z = \{ R^2 + (X_L - X_C)^2 \}^{1/2}$

$$Z = \{ R^2 + (\omega L - 1/\omega C)^2 \}^{1/2}$$

- For resonant frequency:-

$$(X_L = X_C)$$

$$X_L = \omega L = 2\pi f_r L$$

$$X_C = 1/\omega C = 1/2\pi f_r C$$

SERIES RESONANT CIRCUIT

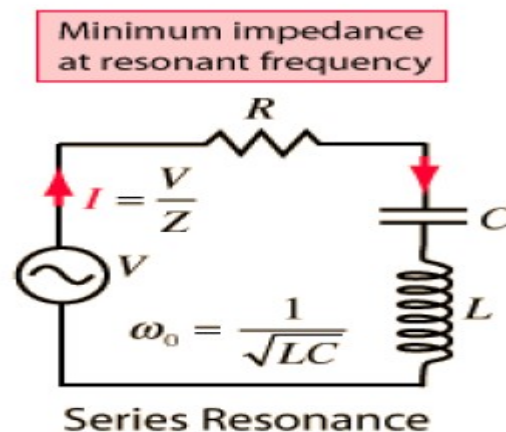

Since at resonance,

$$X_L = X_C$$

$$2\pi f_r L = 1/2\pi f_r C$$

$$f_r = 1/2\pi \sqrt{LC} \quad \omega_r$$

$$f_r = 1/\sqrt{LC}$$

➤ RESONANCE CURVE OF SERIES RESONANT CIRCUIT :

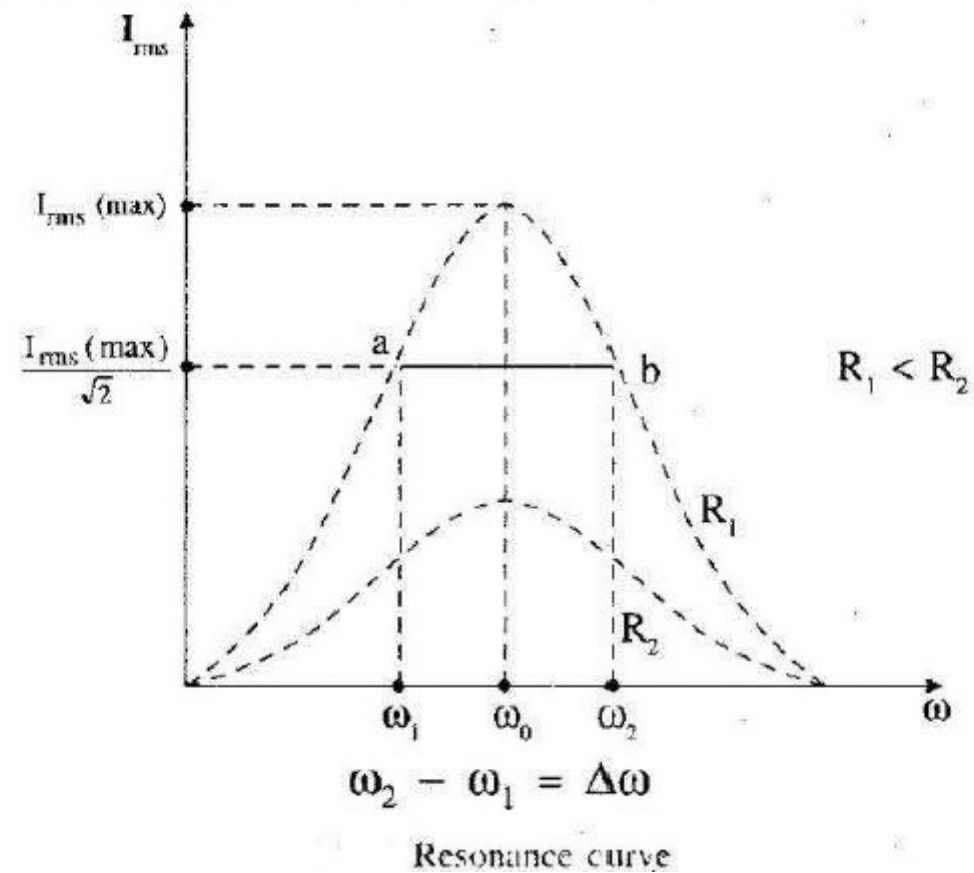

➤ QUALITY FACTOR:

- It is voltage magnification that circuit produces at resonance is called the Q factor.

- Voltage Magnification = $\frac{I_{\max} X_L}{I_{\min} R}$
 = $\boxed{X_L / R}$

- At Resonance =

$$\begin{aligned} X_L / R &= X_C / R \\ \omega_r L / R &= 1 / \omega_r R C \end{aligned}$$

THUS

$$\begin{aligned} Q_r &= \omega_r L / R = 1 / \omega_r R C \\ &= 2 \pi f_r L / R \\ &= (2 \pi L / R) * (1 / 2 \pi \sqrt{LC}) \\ &= \sqrt{L/C} / R \\ &= \boxed{\tan \Phi} \\ &\{ \tan \Phi = \text{power factor of coil} \} \end{aligned}$$

➤ IMPORTANT POINTS

- (1) Net reactance , $X = 0$.
- (2) Impedance $Z = R$.
- (3) Power factor is unity.
- (4) Power expended = 6 watt.
 - Current is so large & will produce large voltage across inductance & capacitance will be equal in magnitude but opposite in phase.
 - Series resonance is called an **acceptor circuit** because such a circuit accepts current at one particular frequency but rejects current at other frequencies these circuit are used in **Radio – receivers** .

Parallel resonance circuit:

PARALLEL OR CURRENT RESONANCE

- When an inductive reactance and a capacitance are connected in parallel condition may reach under which current resonance (also known as parallel or anti-resonance) will take place.
- The frequency at which this happened is known as resonant frequency. Current will be in resonance I reactive component of R -L branch.
- $IR-L \sin\Phi$ R-L = Reactive component of capacitive branch, neglecting leakage reactance of capacitor C.

FREQUENCY V/S IMPEDANCE CURVE FOR LCR CIRCUIT

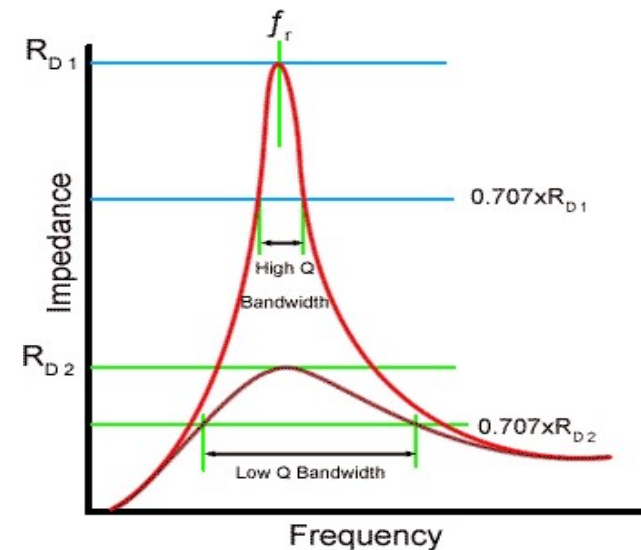
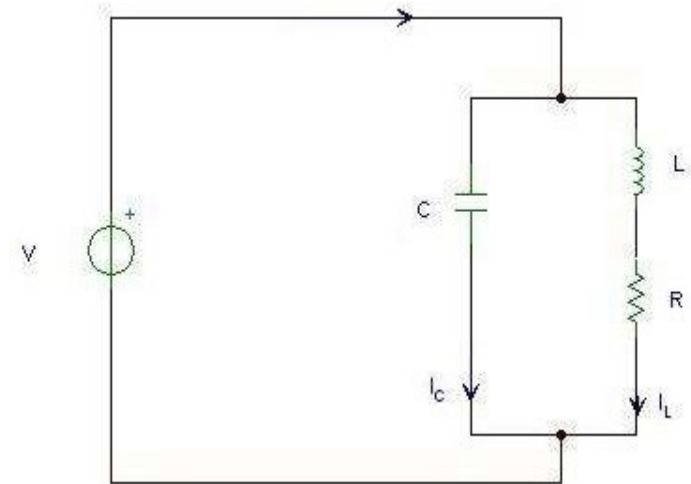

Inductance Quality factor (Q)

Series circuit

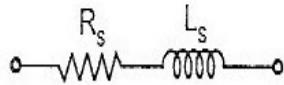

Parallel circuit

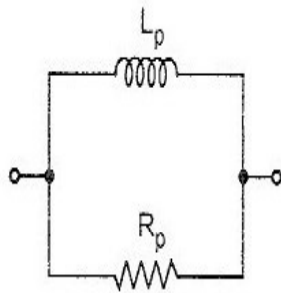

Inductive impedance

$$\frac{\omega L_s}{R_s}$$

Inductive admittance

$$\frac{R_p}{\omega L_p}$$

current

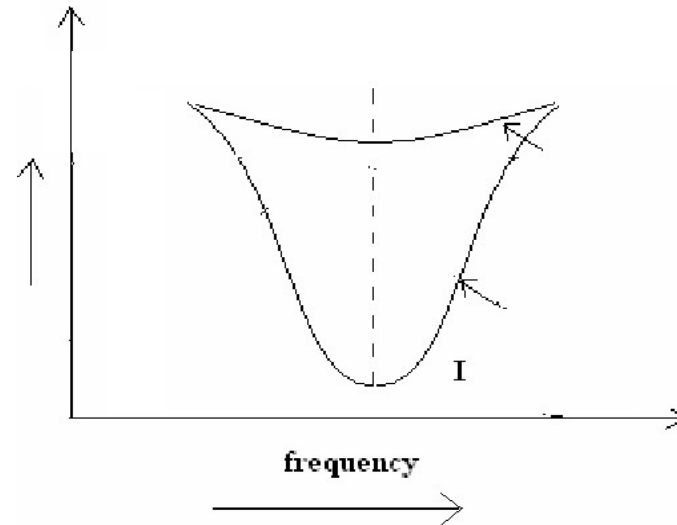

RESONANCE CURVE OF PARALLEL RESONANT CIRCUIT :

3.1.3 Unloaded and Loaded Q

Unloaded Q is the ratio of stored energy to dissipated energy in a reactor or resonator. The unloaded Q or Q_U , of an inductor or capacitor is X/R_s , where X represents the reactance and R_s represents the series resistance. The loaded Q or Q_L , of a resonator is determined by how tightly the resonator is coupled to its terminations.

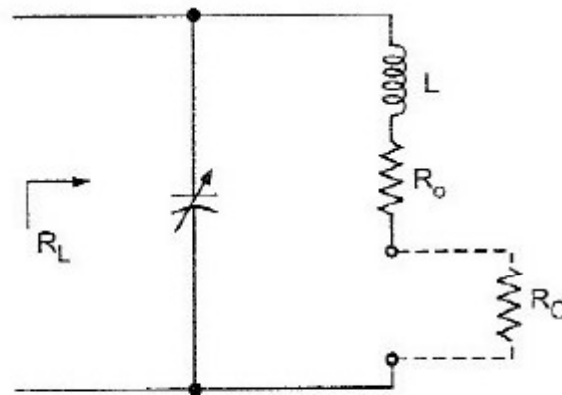

Fig. 3.5 Tuned load circuit

Let us consider the tuned load circuit as shown in the Fig. 3.5. Here, L and C represents tank circuit. The internal circuit losses of inductor are represented by R_o and R_C represents the coupled in load. For this circuit, we can write

$$R_o = \frac{\omega_o L}{Q_U} \text{ and } R_C = \frac{\omega_o L}{Q_L}$$

where Q_U is unloaded Q and Q_L is loaded Q.

The circuit efficiency for the above tank circuit is given as,

$$\eta = \frac{I^2 R_C}{I^2 (R_C + R_o)} = \frac{Q_U}{Q_U + Q_L} \times 100 \%$$

From above equation it can be easily realized that for high overall power efficiency, the coupled-in load R_C should be large in comparison to the internal circuit losses represented by R_o of the inductor.

$$BW = \frac{f_r}{Q_L}$$

where f_r represents the centre frequency of a resonator and BW represents the bandwidth.

If Q is large, bandwidth is small and circuit will be highly selective. For small Q values bandwidth is high and selectivity of the circuit is lost, as shown

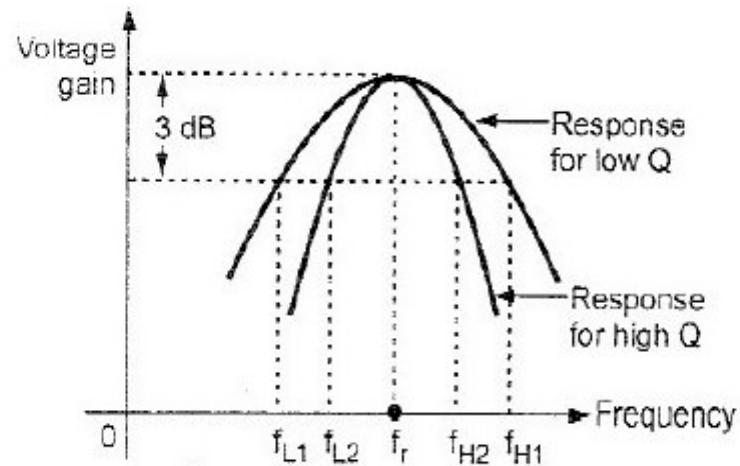

. 3.6 Variation of 3dB bandwidth with variation in quality factor

3.4 Single Tuned Capacitive Coupled .

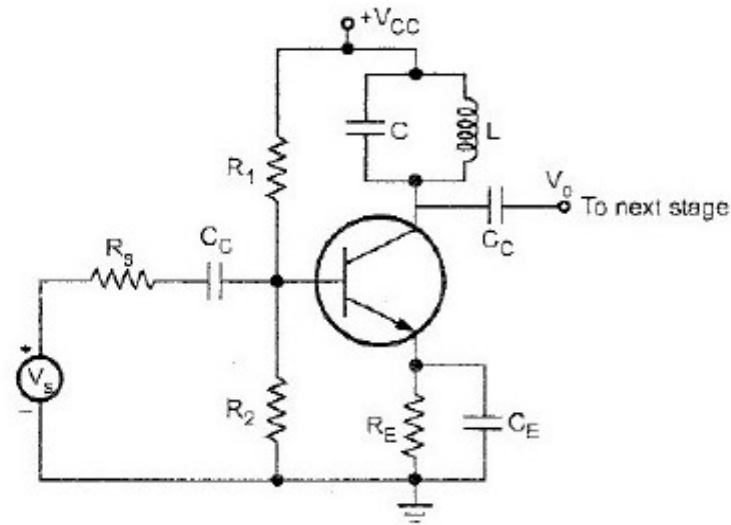

Fig. 3.13 Single tuned capacitive coupled transistor amplifier

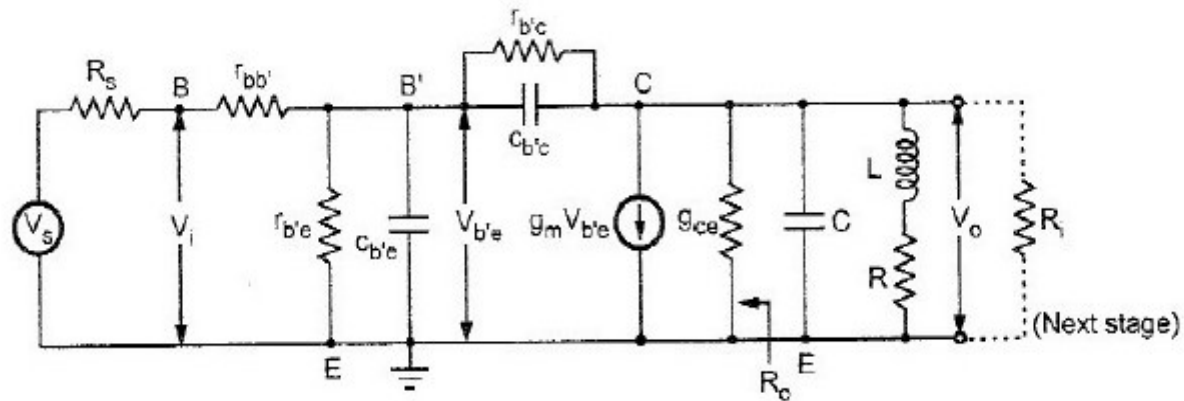

Fig. 3.14 Equivalent circuit of single tuned amplifier

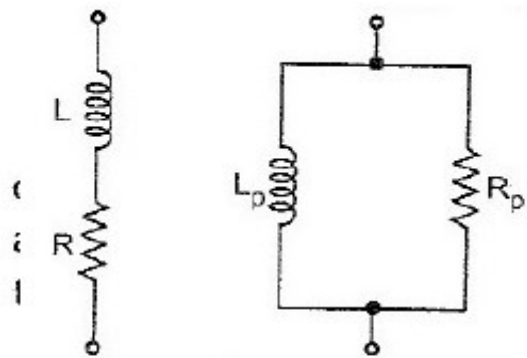

Fig. 3.16

The series RL circuit is represented by its equivalent parallel circuit. The conditions for equivalence are most easily established by equating the admittances of the two circuits shown in Fig. 3.16.

Admittance of the series combination of RL is given as,

$$Y = \frac{1}{R + j\omega L}$$

Multiplying numerator and denominator by $R - j\omega L$ we get,

$$\begin{aligned} Y &= \frac{R - j\omega L}{R^2 + \omega^2 L^2} = \frac{R}{R^2 + \omega^2 L^2} - \frac{j\omega L}{R^2 + \omega^2 L^2} \\ &= \frac{R}{R^2 + \omega^2 L^2} - \frac{j\omega^2 L}{\omega(R^2 + \omega^2 L^2)} \\ &= \frac{1}{R_p} + \frac{1}{j\omega L_p} \end{aligned}$$

where

$$R_p = \frac{R^2 + \omega^2 L^2}{R}$$

and

$$L_p = \frac{R^2 + \omega^2 L^2}{\omega^2 L}$$

$$R_p = \frac{\omega_r^2 L^2}{R}$$

$$= \omega_r Q_r L \quad \because Q_r = \frac{\omega_r L}{R}$$

Therefore, Q_r can be expressed in terms of R_p as,

$$Q_r = \frac{R_p}{\omega_r L}$$

Centre frequency

The centre frequency or resonant frequency is given as,

$$f_r = \frac{1}{2\pi\sqrt{L_p C_{eq}}}$$

Voltage gain (A_v)

The voltage gain for single tuned amplifier is given by,

$$A_v = -g_m \frac{r_{b'e}}{r_{bb'} + r_{b'e}} \times \frac{R_t}{1 + 2jQ_{eff}\delta}$$

where

$$R_t = R_o || R_p || R_i$$

δ = Fraction variation in the resonant frequency

$$A_v \text{ (at resonance)} = -g_m \frac{r_{b'e}}{r_{bb'} + r_{b'e}} \times R_t$$

$$\therefore \left| \frac{A_v}{A_v \text{ (at resonance)}} \right| = \frac{1}{\sqrt{1 + (2\delta Q_{eff})^2}} \quad \dots (14)$$

3 dB bandwidth

The 3 dB bandwidth of a single tuned amplifier is given by,

$$\begin{aligned} \Delta f &= \frac{1}{2\pi R_t C_{eq}} \\ &= \frac{\omega_r}{2\pi Q_{eff}} \quad \because Q_{eff} = \omega_r R_t C_{eq} \quad \dots (15) \end{aligned}$$

$$= \frac{f_r}{Q_{eff}} \quad \because \omega_r = 2\pi f_r \quad \dots (16)$$

SINGLE TUNED AMPLIFIER USING FET

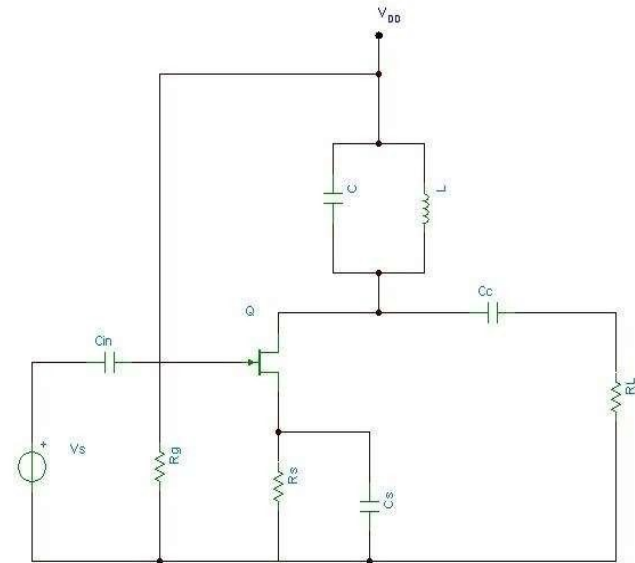

LIMITATION:

- This tuned amplifier are required to be **highly selective**. But high selectivity required a tuned circuit with a high Qfactor.
- A **high Q- factor circuit will give a high A_v but at the same time** , it will give much reduced band with because bandwidth is inversely proportional to the Q- factor .
- It means that tuned amplifier with reduce bandwidth may not be able to amplify equally the complete band of signals & result is poor reproduction . This is called potential instability in tuned amplifier.

Double tuned Amplifier:

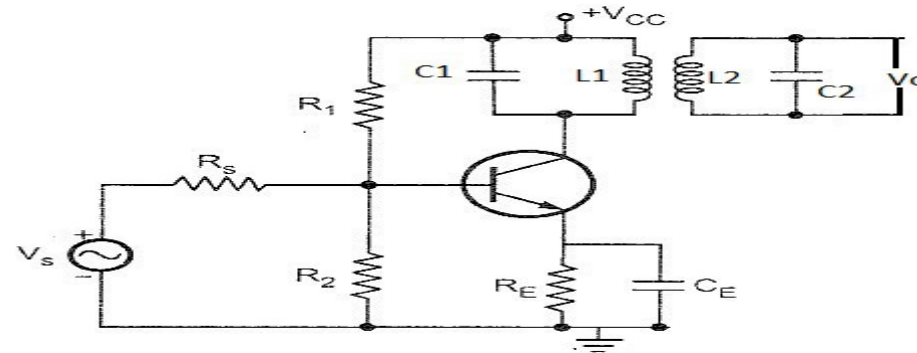

Mutual Inductance

As the current carrying coil produces some magnetic field around it, if another coil is brought near this coil, such that it is in the magnetic flux region of the primary, then the varying magnetic flux induces an EMF in the second coil. If this first coil is called as **Primary coil**, the second one can be called as a **Secondary coil**.

When the EMF is induced in the secondary coil due to the varying magnetic field of the primary coil, then such phenomenon is called as the **Mutual Inductance**.

The figure below gives an idea about this.

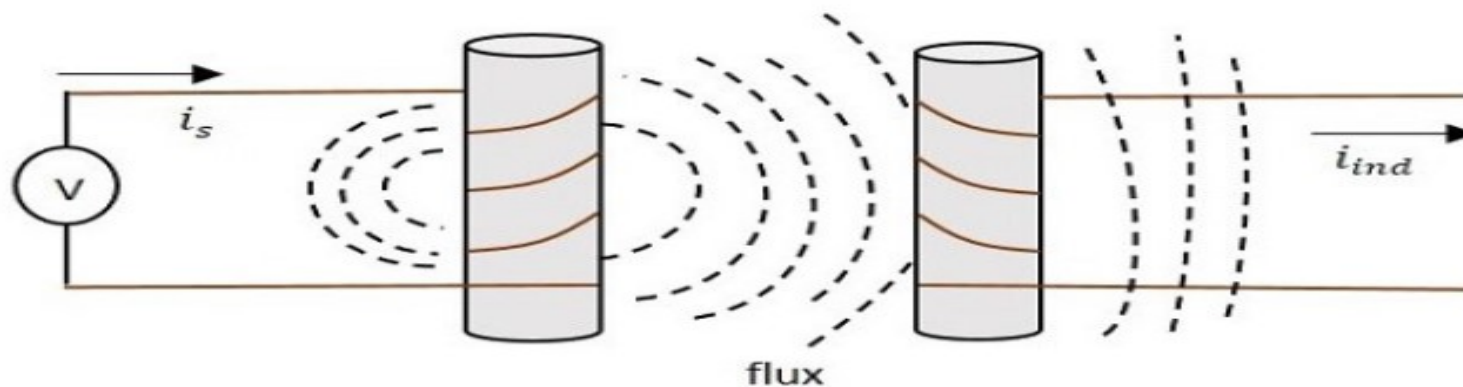

Coupling

Under the concept of mutual inductance coupling will be as shown in the figure below.

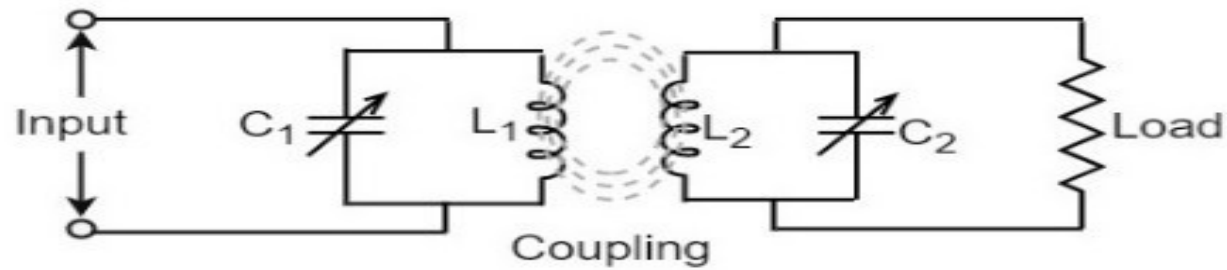

When the coils are spaced apart, the flux linkages of primary coil L_1 will not link the secondary coil L_2 . At this condition, the coils are said to have **Loose coupling**. The resistance reflected from the secondary coil at this condition is small and the resonance curve will be sharp and the circuit Q is high as shown in the figure below.

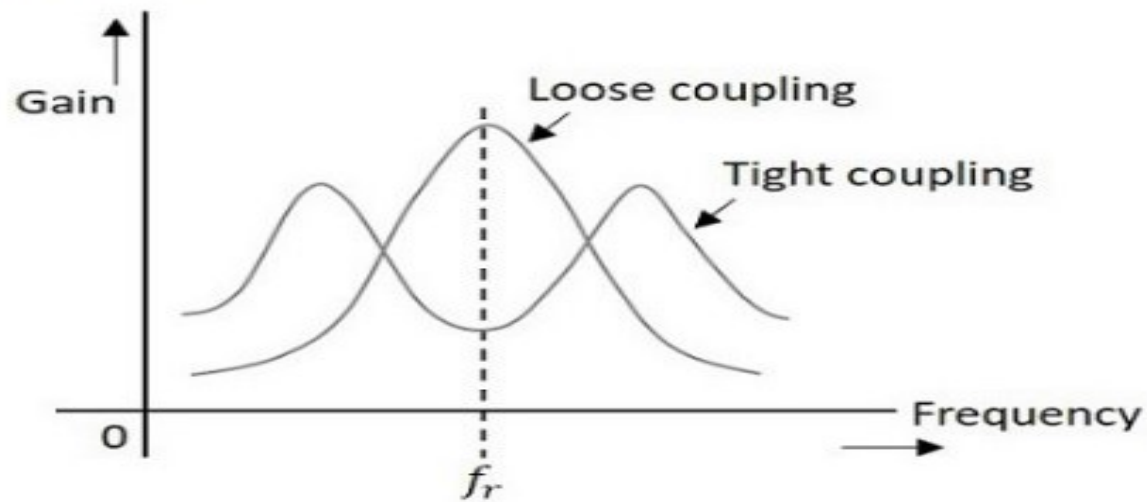

Bandwidth of Double Tuned Circuit

The above figure clearly states that the bandwidth increases with the degree of coupling. The determining factor in a double tuned circuit is not Q but the coupling.

We understand that, for a given frequency, the tighter the coupling the greater the bandwidth will be.

The equation for bandwidth is given as

$$BW_{dt} = kf_r$$

Where BW_{dt} = bandwidth for double tuned circuit, K = coefficient of coupling, and f_r = resonant frequency.

We hope that now you have gained sufficient knowledge regarding the functioning of tuned amplifiers. In the next chapter, we will learn about feedback amplifiers.

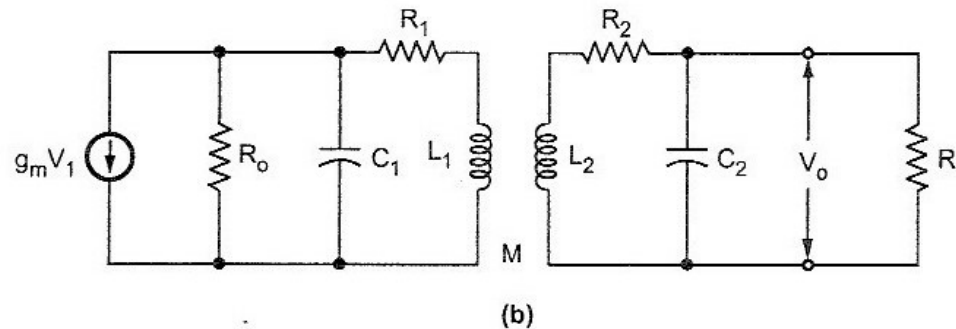

We know that, $Q = \frac{\omega_r L}{R}$

Therefore, the Q factors of the individual tank circuits are

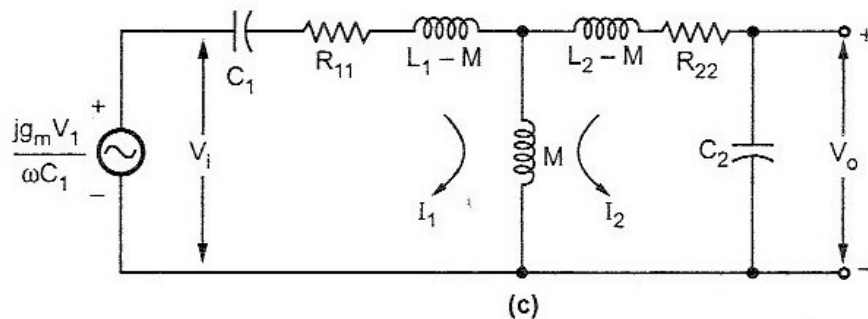

$$Q_1 = \frac{\omega_r L_1}{R_{11}} \text{ and } Q_2 = \frac{\omega_r L_2}{R_{22}}$$

We know that, the 3 dB bandwidth for single tuned amplifier is $2 f_r/Q$. Therefore, the 3 dB bandwidth provided by double tuned amplifier ($3.1f_r/Q$) is substantially greater than the 3 dB bandwidth of single tuned amplifier.

Compared with a single tuned amplifier, the double tuned amplifier

1. Possesses a flatter response having steeper sides.
2. Provides larger 3 dB bandwidth.
3. Provides large gain-bandwidth product.

STAGGER TUNED AMPLIFIERS :

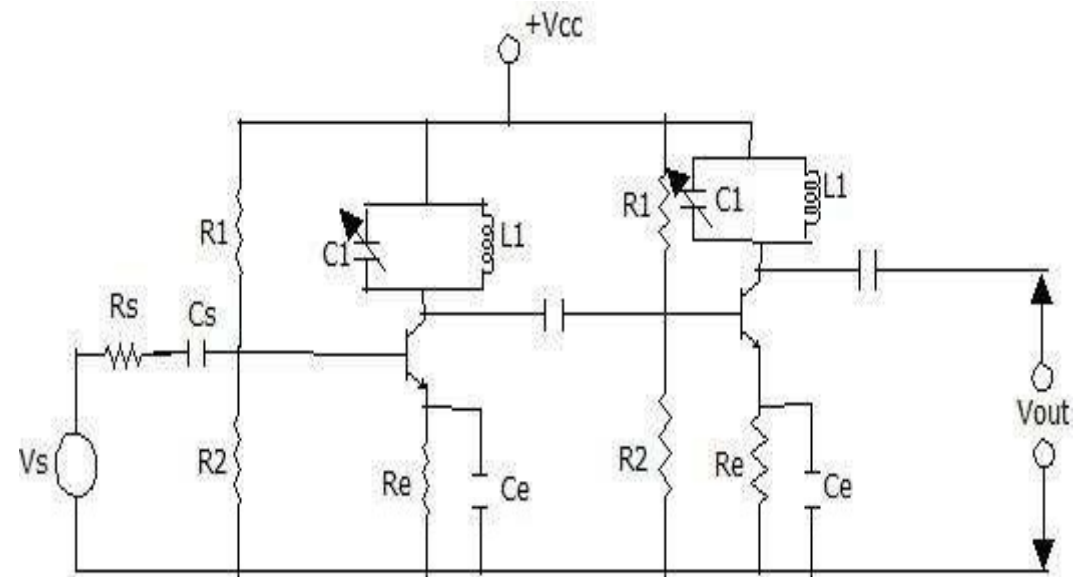

3.8 Staggered Tuned Amplifier

We have seen that double tuned amplifier gives greater 3 dB bandwidth having steeper sides and flat top. But alignment of double tuned amplifier is difficult. To overcome this problem two single tuned cascaded amplifiers having certain bandwidth are taken and their resonant frequencies are so adjusted that they are separated by an amount equal to the bandwidth of each stage. Since the resonant frequencies are displaced or staggered, they are known as staggered tuned amplifiers. The advantage of staggered tuned amplifier is to have a better flat, wideband characteristics in contrast with a very sharp, rejective, narrow band characteristic of synchronously tuned circuits (tuned to same resonant frequencies). Fig. 3.23 shows the relation of amplification characteristics of individual stages in a staggered pair to the overall amplification of the two stages.

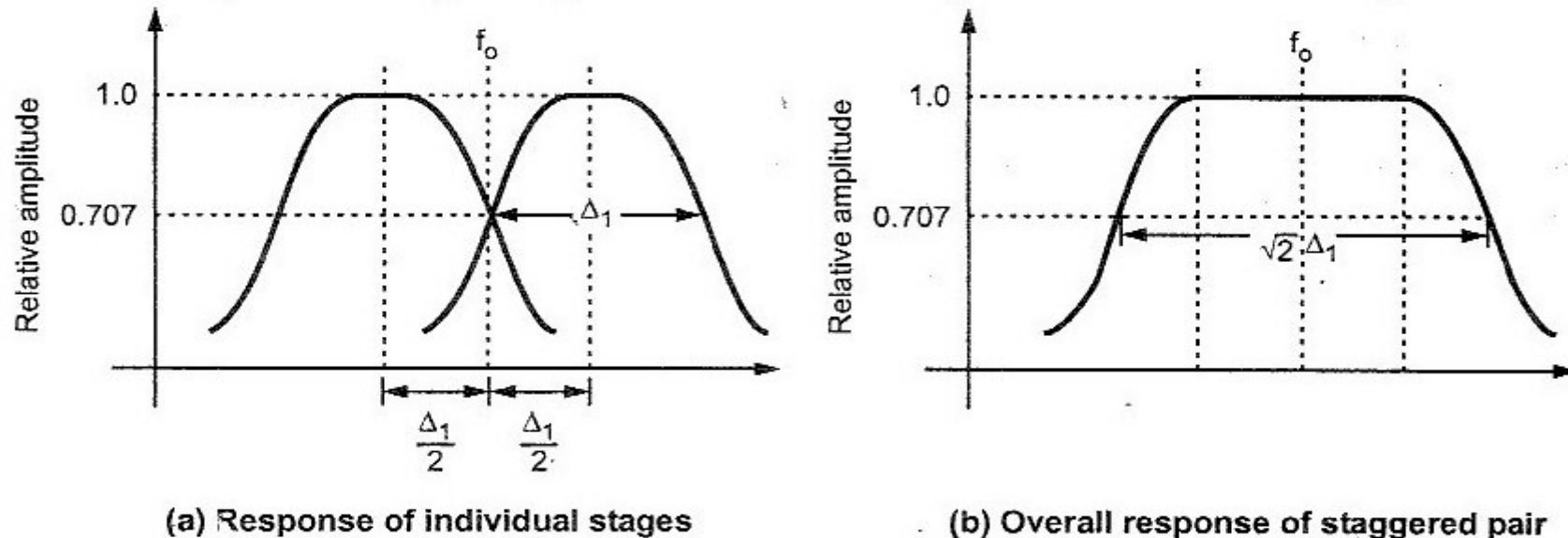

Fig. 3.23

The overall response of the two stage stagger tuned pair is compared in Fig. 3.24 with the corresponding individual single tuned stages having same resonant circuits. Looking at Fig. 3.24, it can be seen that staggering reduces the total amplification of the centre frequency to 0.5 of the peak amplification of the individual stage and at the centre frequency each stage has an amplification that is 0.707 of the peak amplification of the individual stage. Thus the equivalent voltage amplification per stage of the staggered pair is 0.707 times as great as when the same two stages are used without staggering. However,

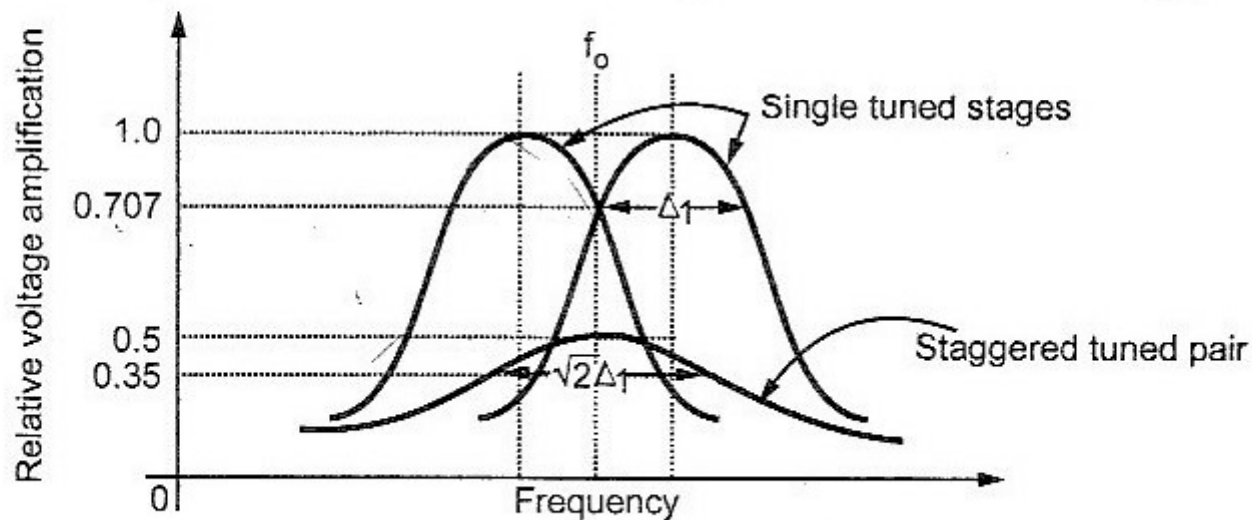

Fig. 3.24 Response of individually tuned and staggered tuned pair

APPLICATIONS OF TUNED AMPLIFIER

Tuned amplifiers serve the best for two purposes:

- a) Selection of desired frequency.
- b) Amplifying the signal to a desired level.

USED IN:

- Communication transmitters and receivers.
- In filter design :--Band Pass, low pass, High pass and band reject filter design.

ADVANTAGES

- It provides high selectivity.
- It has small collector voltage.
- Power loss is also less.
- Signal to noise ratio of O/P is good.
- They are well suited for radio transmitters and receivers .

QUESTIONS ARE WELCOME